



ATG Electronics® DynColor™ 300-FS RGB DMX Controllers

USER GUIDE

Part Number HCD-00300-000000-FS



NOTE:

This user guide is to explain the steps necessary to use the specified and assure peak performance. Its intended use is for reference only, by a fully qualified electrician or technician. This document should never be considered a substitute for any provision of a regulation or state and/or local code.

Please read this entire manual to fully understand and safely use this product.

Specifications are subject to change without notice. Please visit www.atgelectronics.com for most recent user guide versions.

GETTING STARTED

ATG Electronics® DynColor™ 300 Series RGB DMX Controllers are designed specially for manage most RGB LED products of ATG Electronics.

DynColor™ 300-FS (Part Number: HCD-00300-000000-FS) is compatible with iLinear™ R60T RGB LED Ribbon Strips, iSignage™ 36T RGB LED Flex Strips, eCove™ WP27T RGB LED Rigid Strips, eCove™ T30T RGB LED Rigid Strips and oSignage™ WP6T RGB LED Modules.

Based on high performance microprocessor technology, supporting standard DMX512 protocol, it is available for cross-platform operation on DMX console or DMX simulation software (our DMX Controllers support most DMX consoles and DMX simulation software, A TEST-OPERATION IS HIGHLY RECOMMENDED.) With this enhanced tool, you can manage and design color changing patterns and changing speeds from across platforms.

With over 30 preprogrammed color changing patterns, including gradual changing, screening and jumping. As a powerful color managing controller, it will enable you to choose the desired pattern and according speed to manage the RGB lighting fixtures.

With 0 to 100 dimming grades, you can also control the color and brightness according to your requirements easily, to mix up to 1 million different colors.

The LCD monitor on the controller offers an easy and visible managing method; the mounting bracket will enable the operator to easily fix the controller onto any place.

This guide contains important information about installing and operating your new DynColor™ 300-FS safely and accurately.

ATG
Electronics Corp.

Light your world
Color your life!

Included in this Box

DynColor™ 300-FS RGB DMX Controller, 1 PCs
User Guide, 1 Set

Unpacking

- 1) Unpack and carefully examine the product.
- 2) Report any damage and save all packing materials if any part is damaged during transport.
- 3) Do not attempt to use this apparatus if it is damaged.

Warnings

- 1) Risk of electric shock. Ensure that the power supply is off when wiring or soldering the sections of the device.
- 2) The device shall be installed and operated by a qualified electrician or technician in accordance relevant local codes.

Precautions

- 1) Please avoid installing the device in lightening, intense magnetic and high-voltage fields.
- 2) The device should be installed indoors. Otherwise, please arrange rain shielding.
- 3) Make sure the wires are connected correctly and avoid short cut and burnt out the fuse.

User Responsibilities

The responsibility of complying with all state and local laws, ordinances, and regulations in regards to the installation, maintenance, and operation of the device lies with the buyer and handler of the device. These parties may include, but are not limited to the contractor, installer, purchaser, owner, and user of the product.

Note:

The instructions and precautions set forth in this user guide are not necessarily all-inclusive, all conceivable, or relevant to all applications as ATG Electronics cannot anticipate all conceivable or unique situations.

PLANNING THE INSTALLATION

This device installation requires planning to ensure timely, successful installation with minimal complications and down time.

Planning Suggestions

Consult an Electrical Inspector to review all wiring plans.
Create a Layout Plan drawing, per a Lighting Designer's or Architect's recommendation.
Consult ATG Electronics Application Engineering Services as needed.

Installation Considerations

When creating your installation plan, consider the following:

- 1) Location of the controller
ATG Electronics recommends that the controller is placed in dry environment.

2) Selection of soldering tools

Ensure that the tool selected is appropriate for the soldering surface.

3) Maximum Driving Quantity

Product	Driving Quantity per series-wound (Max.)	Total Driving Quantity (Max.)	Output Power of Power Supply (Min.)
iLinear™ R60T RGB LED Ribbon Strips	1 roll	7 roll	350W
iSignage™ 36T RGB LED Flex Strips	15 pcs	105 pcs	350W
eCove™ WP27T RGB LED Rigid Strips	20 pcs	140 pcs	350W
eCove™ T30T RGB LED Rigid Strips (24VDC)	10 pcs	80 pcs	650W
oSignage™ WP6T RGB LED Modules	60 pcs	420 pcs	350W

If you need drive more than above length, QColor™ 310-PE Signal Amplifier(s) is needed.

Installation Steps

- 1) Make sure the switch is keeping off before wiring or installation.
- 2) Connect the RGB fixtures via data wire onto the right interface on the controller; make sure red wire is connected to “RED” interface, blue wire to “BLUE” interface, green wire to “GREEN” interface and black (or white) wire to the “COM+” interface.
- 3) Connect power supply to the input interface of the controller; make sure the positive wire is connected to “DC+” interface and negative wire to “DC-“ interface.
- 4) Plug the power supply into power outlet to switch on the controller.
- 5) Choose the desired color pattern, and set changing speed etc.

Wiring Diagram

1. LED Strips:

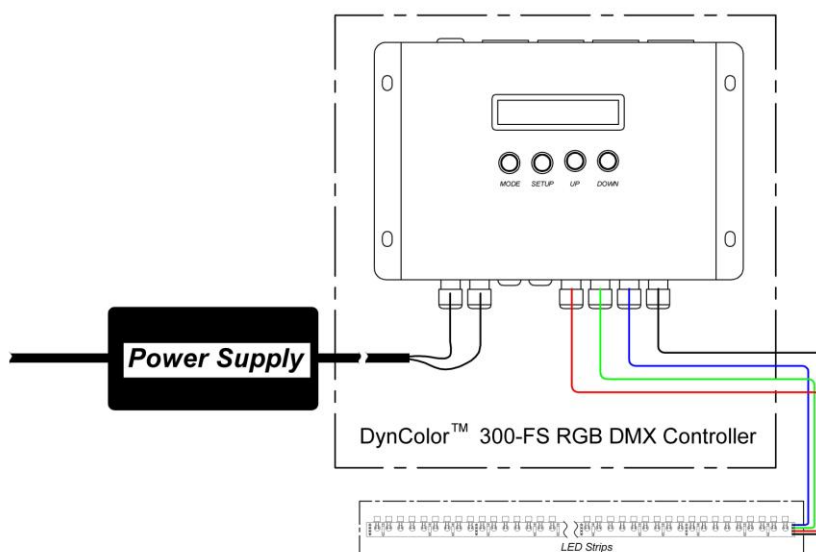

2. LED Modules:

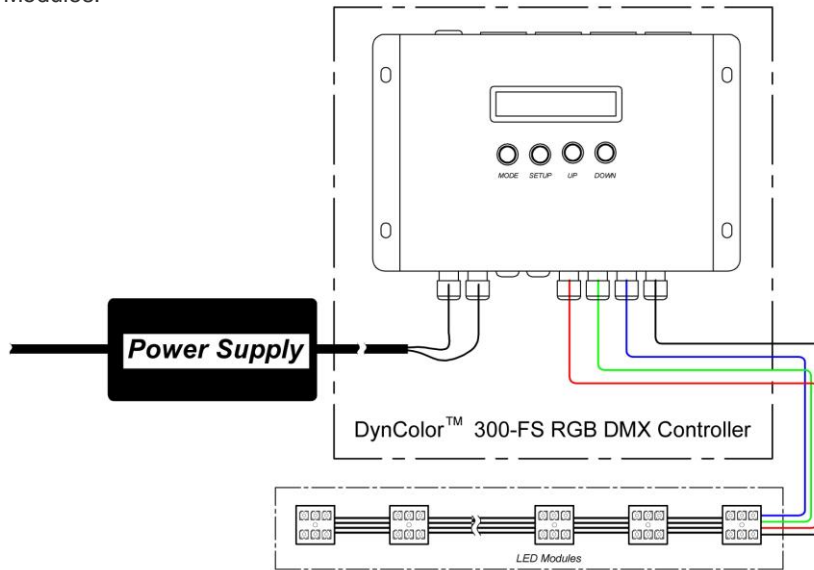

DynColor™ 300-FS RGB DMX Controller is compatible with QColor™ 310-PE Signal Amplifier. You can choose one of the three connecting methods, when quantity of RGB products, like strips, modules etc, need to work together, from below wiring diagrams. (Here we only illustrate LED Strips as example)

1st Connecting Method:

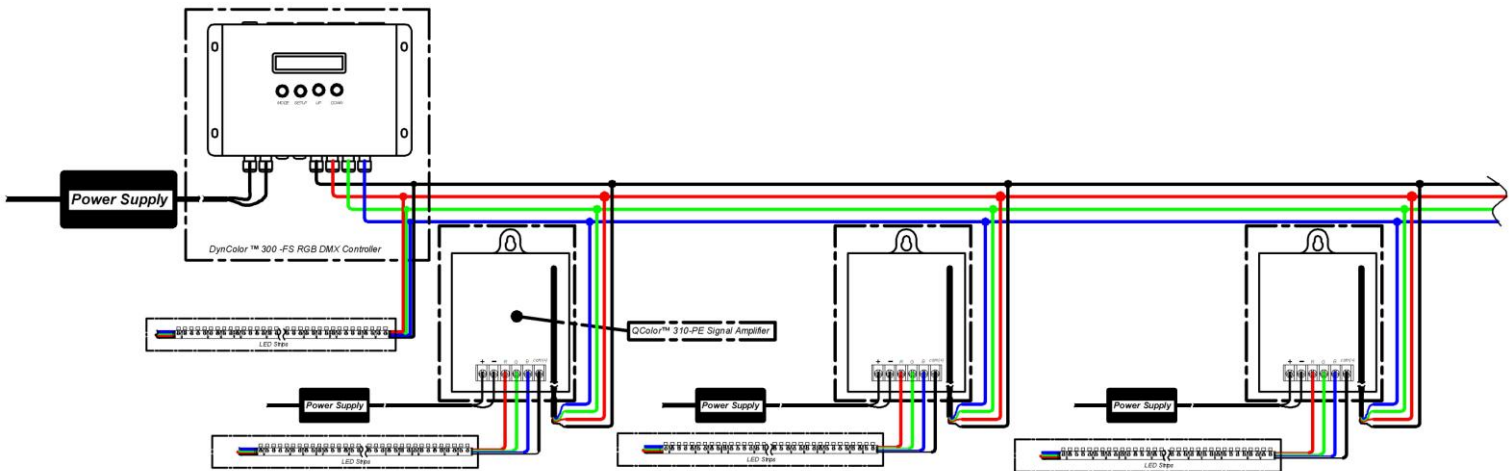

2nd Connecting Method:

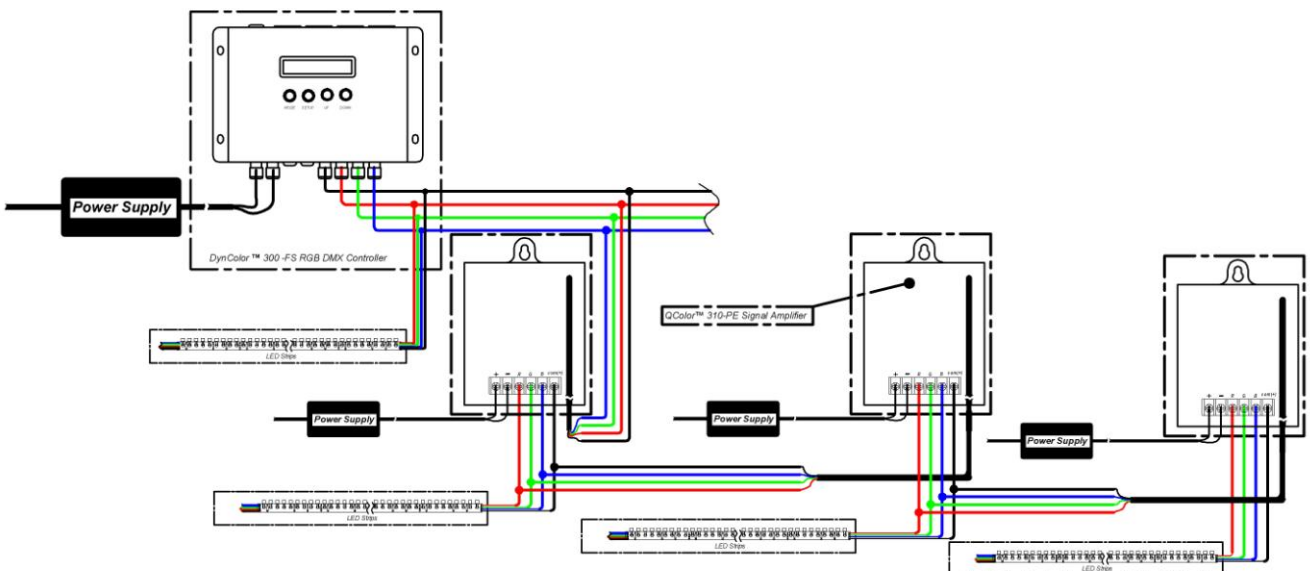

3rd Connecting Method:

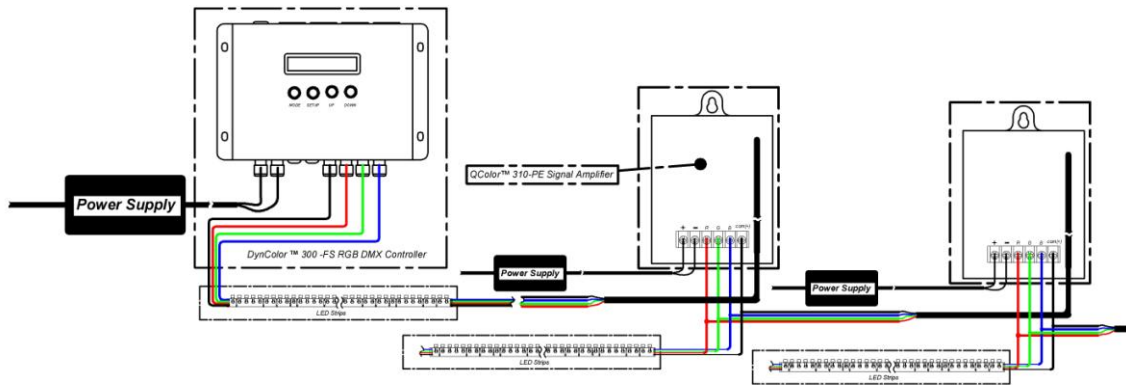

Function Introduction

1) Physical Specifications

Dimension: L190 x W120 x H50 mm

Weight: 830g

Working Environment: dry environment

Buttons: MODE, SETUP, UP & DOWN

Data Interfaces: DMX512

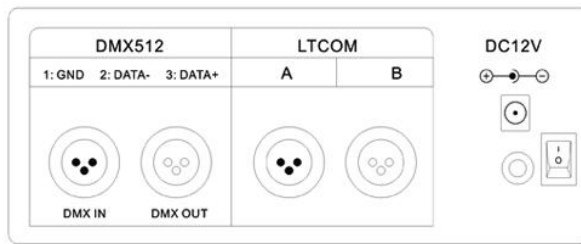

Front View

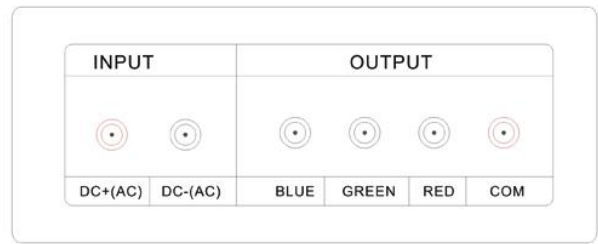

Back View

3) Function of Buttons

MODE: Select the preferred pre-programmed color pattern.

SETUP: Set the parameters of selected color pattern.

UP: Increase the parameter step by step

DOWN: Decrease the parameter step by step

4) Button "MODE" Introduction

Serial NO.	Displayed Content	Description
1	BLACK	Static Black
2	STATIC RED	Static Red
3	STATIC GREEN	Static Green
4	STATIC BLUE	Static Blue
5	STATIC YELLOW	Static Yellow
6	STATIC PURPLE	Static Purple
7	STATIC CYAN	Static Cyan
8	STATIC WHITE	Static White
9	COLOR CHANGE	7 Color Jumping

10	COLOR CHANGE2	7 Color Flicker
11	SIX COLOR	6 Color Jumping
12	SIX COLOR 2	6 Color Flicker
13	RGB CHANGE	3 Color Jumping
14	RGB CHANGE2	3 Colors Flicker
15	RG CHANGE	Red & Green Jumping
16	RB CHANGE	Red & Blue Jumping
17	GB CHANGE	Green & Blue Jumping
18	WHITE FLASH	White Flicker
19	COLOR SMOOTH	7 Color Gradual Changing
20	RGB SMOOTH	3 Color Gradual Changing
21	RG SMOOTH	Red & Green Gradual Changing
22	RB SMOOTH	Red & Blue Gradual Changing
23	GB SMOOTH	Green & Blue Gradual Changing
24	COLOR GRADUAL	7 Color Fade In /Fade Down
25	RGB GRADUAL	3 Color Fade In /Fade Down
26	WHITE GRADUAL	White Color Fade In /Fade Down
27	RG GRADUAL	Red & Green Fade In /Fade Down
28	RB GRADUAL	Red & Blue Fade In /Fade Down
29	GB GRADUAL	Green & Blue Fade In /Fade Down
30	R GRADUAL	Red Fade In /Fade Down
31	G GRADUAL	Green Fade In /Fade Down
32	B GRADUAL	Blue Fade In /Fade Down
33	ADJUST MODE	Adjust the brightness of red, green & blue
34	AUTO PROGRAM	Combine selected patterns, run them automatically & circularly.
35	DMX512 MODE	Select preferred pattern and manage it remotely from DMX console.
36	DMX512 DECODER	Decoder mode activated, receive data from DMX console. Program preferred pattern, manage red, green & blue channels individually on the console.

5) Button "SETUP" Introduction

MODE 1-8 is static color without setup function.

Serial NO.	Displayed Content	Instruction	Description
1	INTERVAL	0 to 100	Interval between 2 patterns
2	RUN SPEED	0 to 100	Run speed
3	FLASH	0 to 100	Flash frequency
4	LOAD DEFAULT	YES or NO	Load default parameters
5	AUTO SELECT	YES or NO	If you want this pattern appeared in AUTO PROGRAMME, select YES, otherwise NOT
6	TUBE QTY	0-4000	Select the actual tube quantity you have

6) How to set the DMX controller under DMX512 mode?

Under DMX512 mode, the DMX controller occupies 2 channels/addresses. The first channel/address is for mode selection; the second channel/address is for speed selection.

Please follow the below steps to set up your DMX controller:

- ① Set DMX controller to DMX512 MODE;
- ② Set DMX channel/address for the DMX controller: if the DMX channel/address is set to 13, the controller will occupy channel/address 13 & 14; if the DMX channel/address is set to 128, the controller will occupy channel/address 128 & 129;
- ③ Manage the first channel/address on the DMX console, like 13 or 128, to select the preferred pattern to use;
- ④ Manage the second channel/address on the DMX console, like 14 or 129, to set the changing speed.

7) How to set the DMX controller under DMX512 DECODER mode?

Under DMX512 DECODER mode, the DMX controller occupies 3 channels/addresses. The first channel/address is for adjusting brightness of red color; the second channel/address is for adjusting brightness of green color; the third channel/address is for adjusting brightness of blue color.

- ① Set DMX controller to DMX512 DECODER mode;
- ② Set DMX channel/address for the DMX controller: if the DMX channel/address is set to 13, the controller will occupy channel/address 13, 14 & 15; if the DMX channel/address is set to 128, the controller will occupy channel/address 128, 129 & 130;
- ③ Manage the first channel/address on the DMX console, like 13 or 128, to adjust the brightness of red color;
- ④ Manage the second channel/address on the DMX console, like 14 or 129, to adjust the brightness of green color;
- ⑤ Manage the third channel/address on the DMX console, like 15 or 130, to adjust the brightness of blue color.

QUALITY WARRANTY

This product is sold pursuant to ATG Electronics Standard Terms and Conditions which can be found at www.atgelectronics.com/warranty and which contain important provisions, including, among others, the Quality Warranty, exclusions and limitations on ATG Electronics liability for damages, and restrictions on available remedial actions.

For any after-sales assistance, please contact our Customer Service Team at service@atgelectronics.com. All your concerns and requests will be handled within 12 hours.

628 Zhangyang Road, Suite 1-21B
Shanghai 200122, CHINA
www.atgelectronics.com
E-mail: sales@atgelectronics.com
Phone: +86-21-58350166
Fax: +86-21-58351977

ATG
Electronics Corp.

Light your world
Color your life!