

ATG Electronics® QColor™ 512-DC DMX Decoders

USER GUIDE

Part Number HCD-00512-000000-DC



NOTE:

This user guide is to explain the steps necessary to use the specified and assure peak performance. Its intended use is for reference only, by a fully qualified electrician or technician. This document should never be considered a substitute for any provision of a regulation or state and/or local code.

Please read this entire manual to fully understand and safely use this product.

Specifications are subject to change without notice. Please visit www.atgelectronics.com for most recent user guide versions.

GETTING STARTED

ATG Electronics® QColor™ 512 DMX Decoders adopt advanced microcomputer control technology and converts DMX512/1990 digital signal into analog signal. QColor™ 512 DMX Decoders can convert signal to 256 grade dimming levels, from 0 to 100%, which can meet most project request.

It allows user to choose any channel between 1~512, 256-level brightness control. This compact decoder connects DMX Console to analog devices, enabling user to create endless possibilities of light shows. QColor™ 512-DC is 12VDC~24VDC input and compatible with all DC input RGB LED Lighting Fixtures.

This guide contains important information about installing and operating your new QColor™ 512-DC DMX Decoders safely and accurately.

Physical Dimensions

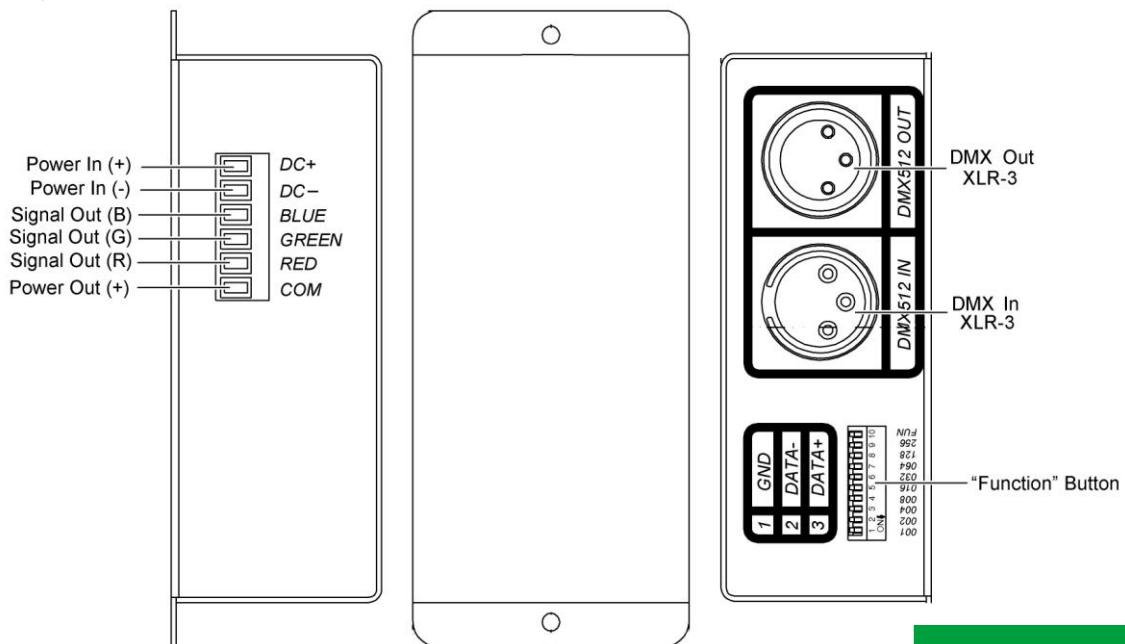

Included in this Box

QColor™ 512-DC DMX Decoder, 1 PCs
User Guide, 1 Set

Unpacking

- 1) Unpack and carefully examine the product.
- 2) Report any damage and save all packing materials if any part is damaged during transport.
- 3) Do not attempt to use this apparatus if it is damaged.

Warnings

- 1) Risk of electric shock. Ensure that the power supply is off when wiring or soldering the sections of the device.
- 2) The device shall be installed and operated by a qualified electrician or technician in accordance relevant local codes.
- 3) Please avoid installing the device in lightning, intense magnetic and high-voltage fields.
- 4) The device should be installed indoors. Otherwise, please arrange rain shielding.
- 5) Make sure the wires are connected correctly and avoid short circuit.

User Responsibilities

The responsibility of complying with all state and local laws, ordinances, and regulations in regards to the installation, maintenance, and operation of the device lies with the buyer and handler of the device. These parties may include, but are not limited to the contractor, installer, purchaser, owner, and user of the product.

Note:

The instructions and precautions set forth in this user guide are not necessarily all-inclusive, all conceivable, or relevant to all applications as ATG Electronics cannot anticipate all conceivable or unique situations.

PLANNING THE INSTALLATION

This device installation requires planning to ensure timely, successful installation with minimal complications and down time.

Planning Suggestions

Consult an Electrical Inspector to review all wiring plans.
Create a Layout Plan drawing, per a Lighting Designer's or Architect's recommendation.
Consult ATG Electronics Application Engineering Services as needed.

Installation Considerations

When creating your installation plan, consider the following:

- 1) Location of the decoder
ATG Electronics recommends that the decoder is placed in dry environment.
- 2) Selection of soldering tools
Ensure that the tool selected is appropriate for the soldering surface.

Installation Steps

- 1) Make sure power is switched off before attempting to wire or install.
- 2) Connect RGB fixtures (12VDC-24VDC, e.g. iSignage™ 36T RGB LED Flex Strip) via signal cables onto the correct ports on the decoder; make sure red wire is connected to “RED” port, blue wire to “BLUE” port, green wire to “GREEN” port and black (or white) wire to the “COM+” port.
- 3) Connect power supply to the decoder; make sure the positive wire is connected to “DC+” port and negative wire to “DC-“ port.
- 4) Connect DMX Console to “DMX IN” port of the decoder.
- 5) Plug power supply into power outlet.
- 6) Set up the address of the decoder. After new address is set up, you should re-start the decoder or re-activate button “FUN” to activate the setting.

Wiring Diagram

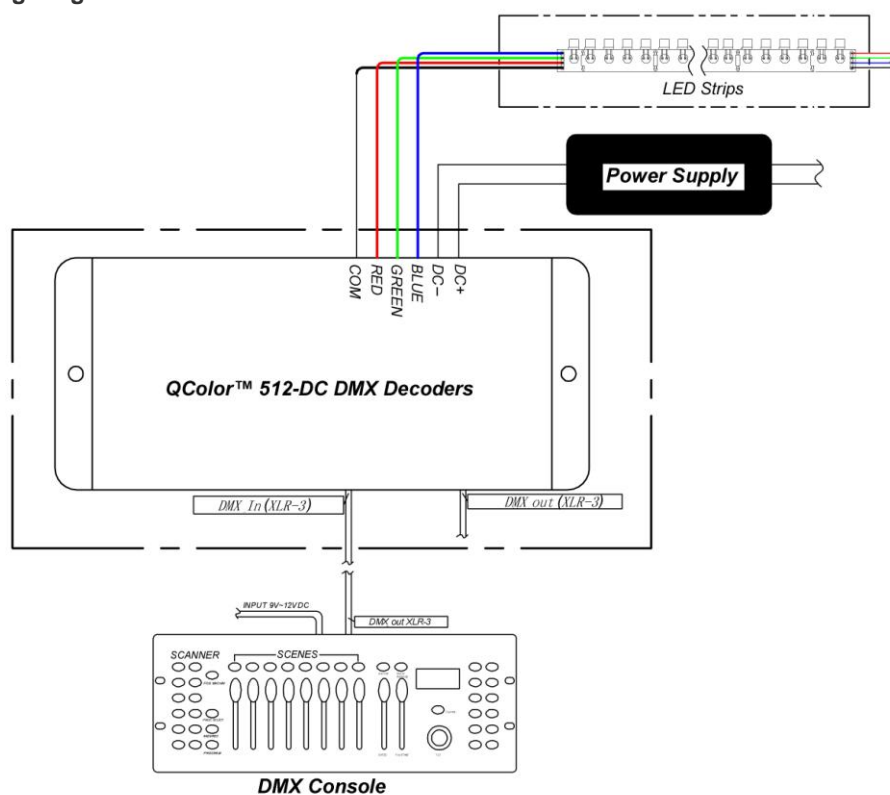

Main Specifications

- Input Voltage: 12~24VDC
- Output Load Current: 3A (Maximum) per line, 3 lines
- Output Power: 0~100W (12VDC), 0~200W (24VDC)
- Operation Temperature: -10°C~50°C (14°F~122°F)
- Dimension: L125*W65*H40 mm
- Weight: 300g
- Work Environment: Indoor dry environment

Button Introduction & DMX Addressing

- 1) “Function” Button
- Button 10: This is the FUN (function) button.

FUN=OFF, the decoder will work under decoder mode, and it will receive signal from connected console.
FUN=ON, the decoder will work under default mode.

2) Decoder mode

FUN=OFF, the decoder will work under decoder mode. The decoder occupies 3 addresses on the console.

How to address the decoder?

For example, if you want to set the decoder to address 37 on the console.

Firstly, switch off button 10 (FUN button)

Then, switch on button 6, 3 and 1. ($32+4+1=37$, see the below picture)

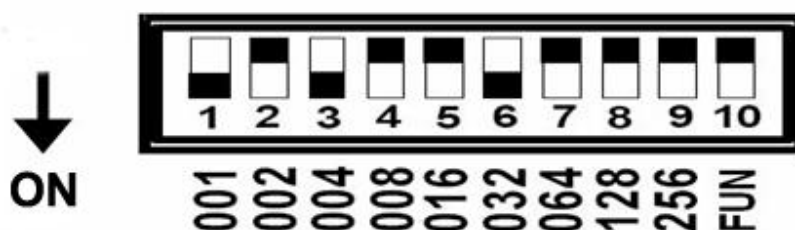

4) Default mode

FUN=ON, the decoder will work under default mode.

Button 1~9=OFF, Black

Button 1=ON, Red

Button 2=ON, Green

Button 3=ON, Blue

Button 4=ON, Yellow

Button 5=ON, Violet

Button 6=ON, Cyan

Button 7=ON, White

Button 8=ON, Triple color changing (2 second interval)

Button 9=ON, Seven color changing (2 second interval)

QUALITY WARRANTY

This product is sold pursuant to ATG Electronics Standard Terms and Conditions which can be found at www.atgelectronics.com/warranty and which contain important provisions, including, among others, the Quality Warranty, exclusions and limitations on ATG Electronics liability for damages, and restrictions on available remedial actions.

For any after-sales assistance, please contact our Customer Service Team at service@atgelectronics.com. All your concerns and requests will be handled within 12 hours.

628 Zhangyang Road, Suite 1-21B

Shanghai 200122, CHINA

www.atgelectronics.com

E-mail: sales@atgelectronics.com

Phone: +86-21-58350166

Fax: +86-21-58351977

ATG
Electronics Corp.

Light your world
Color your life!