



ATG Electronics® oSignage™ WP3 LED Modules

USER GUIDE

Part Number	HMZ-Z003R-007400-L1
	HMZ-Z003Y-007400-L1
	HMZ-Z003B-007400-L1
	HMZ-Z003G-007400-L1
	HMZ-Z003N-007400-L1



NOTE:

This user guide is to explain the steps necessary to use the specified and assure peak performance. Its intended use is for reference only, by a fully qualified electrician or technician. This document should never be considered a substitute for any provision of a regulation or state and/or local code.

Please read this entire manual to fully understand and safely use this product.

Specifications are subject to change without notice. Please visit www.atgelectronics.com for most recent user guide versions.

GETTING STARTED

ATG Electronics® oSignage™ WP series LED Modules are designed for signage lighting and decoration, both indoor and outdoor are applicable; they are ideal alternatives to neon or fluorescent tubes. Color is available in red, yellow, blue, green, white and RGB.

oSignage™ WP3 is oblong shape, with 3LEDs in, and available in solid colors.

oSignage™ WP series LED Modules are 12VDC input; different models of power supplies are available for your choice. (Please visit http://www.atgelectronics.com/lighting/lighting10_20.html for more information.)

oSignage™ WP series LED Modules can be easily installed onto the surface of the channel letters with the 3M double-sided sticking tape on the back. The red-black power cable between each module is 100mm long; they can be cut and powered up at every one piece or re-connected to apply specific length.

oSignage™ WP series LED Modules are IP68 rated, can be submerged into water. When dimming function needed, you can install a QColor™ Remote Dimmer on the main cable.

oSignage™ WP series LED Modules are the ideal products to light up channel letters, signboards, besides, they can be used for under-counter lighting or decoration lighting. They have been successfully used in homes, hotels, restaurants, stores, shops and clubs etc.

This guide contains important information about installing and operating your new oSignage™ WP3 LED Modules safely and accurately.

ATG
Electronics Corp.

Light your world
Color your life!

Included in this Box

oSignage™ WP3 LED Modules, 20 PCs
User Guide, 1 Set

Additional Items Needed

Power Supply: 12 VDC QDriver™/XDriver™ LED Power Supply
Dimming System: QColor™ Remote Dimmer (Part Number: HCD-00001-000000-RD)

Unpacking

- 1) Unpack and carefully examine the product.
- 2) Report any damage and save all packing materials if any part is damaged during transport.
- 3) Do not attempt to use this apparatus if it is damaged.

Warnings

- 1) Risk of electric shock. Ensure that the power supply is off when wiring or soldering the sections of the strip.
- 2) The device shall be installed and operated by a qualified electrician or technician in accordance relevant local codes.

Cautions

- 1) Suggested continuous working time is around 8 hours, never more than 12 hours.
- 2) Do not use sharp tools near or on the surface of the device.

User Responsibilities

The responsibility of complying with all state and local laws, ordinances, and regulations in regards to the installation, maintenance, and operation of the device lies with the buyer and handler of the device. These parties may include, but are not limited to the contractor, installer, purchaser, owner, and user of the product.

Note:

The instructions and precautions set forth in this user guide are not necessarily all-inclusive, all conceivable, or relevant to all applications as ATG Electronics cannot anticipate all conceivable or unique situations.

PLANNING THE INSTALLATION

This device installation requires planning to ensure timely, successful installation with minimal complications and down time.

Planning Suggestions

Consult an Electrical Inspector to review all wiring plans.
Create a Layout Plan drawing, per a Lighting Designer's or Architect's recommendation.
Consult ATG Electronics Application Engineering Services as needed.

Installation Considerations

When creating your installation plan, consider the following:

1) Location of the device

oSignage™ WP3 is suitable for both indoor and outdoor applications with IP68 degree.

2) Maximum series-wound quantity

60 pcs.

Installation Steps

1) Remove the 3M tape from the back of oSignage™ WP3 LED Modules.

2) Place and fix oSignage™ WP3 LED Modules to the defined area according to project layout.

3) Connect the power supply to the oSignage™ WP3 LED Modules.

4) Plug power supply into power outlet to light the whole system.

Wiring Diagram

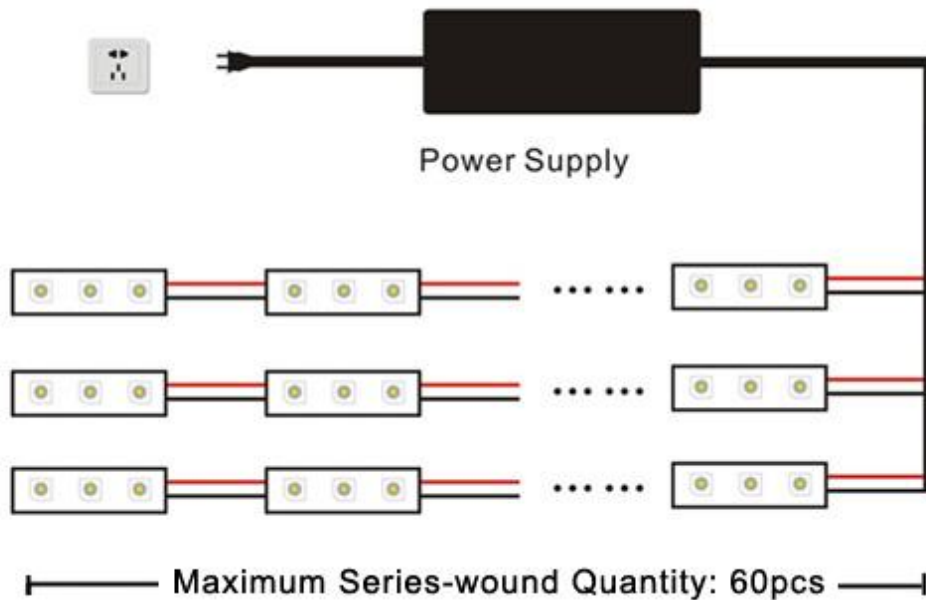

ATG Electronics® oSignage™ WP3 LED Modules Specifications

Operation Voltage: 12 VDC

Color: Red, Yellow, Blue, Green, White

LED Qty: 3 LEDs

Lumens: 3.06~11.4 lm

Power Consumption: 0.24 W

Dimension: L61*W18*H12 mm (L2.4*W0.71*H0.47 inch)

Beam Angle: 80°

IP Rating: IP68 (submersible)

* Detailed specifications please refer to the product catalog of oSignage™ WP3 LED Modules.

LED SOURCE LIFE

Traditionally, the definition of life for light sources is defined at the point which 50% of the lamps fail under

www.atgelectronics.com

the time. According to the industry standard, ATG Electronics uses the concept of useful light output and rates product life time at standard of “less than 50% lumen maintenance of original light output”.

LED exhibits very long operational life time, typically 50,000 hours or more. However, like all light source, LED light output can degrades and also undergo gradual shifts in color over time.

LED chips, performed lighting effects and working environmental conditions, such as temperature, humidity, and ventilation will affect LED lumen maintenance. The overall LED Lighting System life time could vary substantially based on usage and environmental condition.

ATG Electronics always adopts brand chips and high quality materials and components to make LED Lighting Systems.

QUALITY WARRANTY

This product is sold pursuant to ATG Electronics Standard Terms and Conditions which can be found at www.atgelectronics.com/warranty and which contain important provisions, including, among others, the Quality Warranty, exclusions and limitations on ATG Electronics liability for damages, and restrictions on available remedial actions.

For any after-sales assistance, please contact our Customer Service Team at service@atgelectronics.com. All your concerns and requests will be handled within 12 hours.

628 Zhangyang Road, Suite 1-21B
Shanghai 200122, CHINA
www.atgelectronics.com
E-mail: sales@atgelectronics.com
Phone: +86-21-58350166
Fax: +86-21-58351977

ATG
Electronics Corp.

Light your world
Color your life!